Application Note: AN00120

XMOS 100Mbit Ethernet application note

Ethernet connectivity is an essential part of the explosion of connected devices known collectively as the Internet of Things (IoT). XMOS technology is perfectly suited to these applications - offering future proof and reliable ethernet connectivity whilst offering the flexibility to interface to a huge variety of "Things".

This application note shows a simple example that demonstrates the use of the XMOS Ethernet library to create a layer 2 ethernet MAC interface on an XMOS multicore microcontroller.

The code associated with this application note provides an example of using the Ethernet Library to provide a framework for the creation of an ethernet Media Independent Interface (MII) and MAC interface for 100Mbps.

The application note uses XMOS libraries to provide a simple IP stack capable of responding to an ICMP ping message. The code used in the application note provides both MII communication to the PHY and a MAC transport layer for ethernet packets and enables a client to connect to it and send/receive packets.

Required tools and libraries

- xTIMEcomposer Tools - Version 14.0.0
- XMOS Ethernet library - Version 3.0.0
- XMOS OTP Reading Library - Version 2.0.0
- XMOS sliceKIT Board Support Library - Version 2.0.0

Required hardware

This application note is designed to run on an XMOS xCORE-L (General Purpose family) series device. The example code provided with the application has been implemented and tested on the xCORE-L2 sliceKIT 1V2 (XP-SKC-L2) core board using ethernet sliceCARD 1V1 (XA-SK-E100). There is no dependency on this core board - it can be modified to run on any (XMOS) development board which has the option to connect to the ethernet sliceCARD.

Prerequisites

- This document assumes familiarity with the XMOS xCORE architecture, the Ethernet standards IEEE 802.3u (MII), the XMOS tool chain and the xC language. Documentation related to these aspects which are not specific to this application note are linked to in the references appendix.
- For a description of XMOS related terms found in this document please see the XMOS Glossary¹.
- For an overview of the Ethernet library, please see the Ethernet library user guide.

¹<http://www.xmos.com/published/glossary>

1 Overview

1.1 Introduction

The application note shows the use of the XMOS Ethernet library. The library allows multiple clients to access the Ethernet hardware. This application note uses the standard Ethernet MAC which uses two logical cores. The Ethernet library also provides a real-time MAC which uses more cores but provides high performance streaming data, accurate packet timestamping, priority queuing and 802.1Qav traffic shaping.

MII provides the data transfer signals between the Ethernet PHY (Physical Layer Device or transceiver) and the xCORE device. The MII layer receives packets of data which are then routed by an Ethernet MAC layer to multiple processes running on the xCORE. SMI provides the management interface between the PHY and the xCORE device.

1.2 Block Diagram

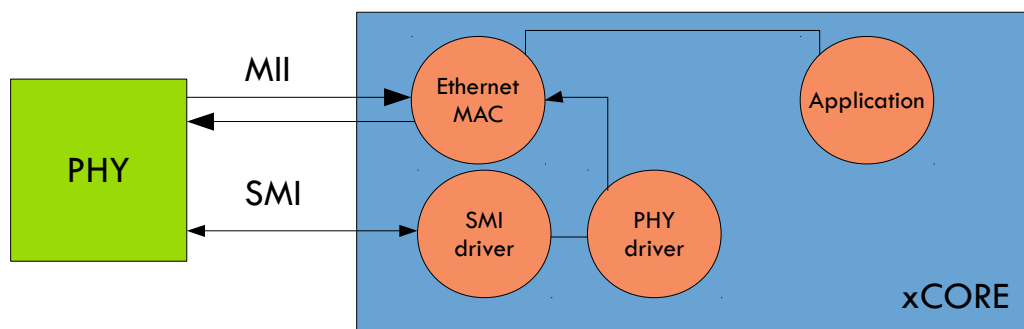

Figure 1: Application block diagram

The application communicates with the Ethernet MAC that drives the MII data interface to the PHY. A separate PHY driver configures the PHY via the SMI serial interface.

2 100Mbit Ethernet library demo

2.1 The Makefile

The demo in this note uses the XMOS Ethernet library and shows a simple program communicating with the Ethernet library.

To start using the Ethernet library, you need to add `lib_ethernet` to you Makefile:

```
USED_MODULES = .. lib_ethernet ...
```

This demo also gets the MAC address out of the xCORE OTP rom and is for the sliceKIT. So the Makefile also includes the OTP reading library (`lib_otpinf`) and the sliceKIT support library (`lib_sliceKIT_support`):

```
USED_MODULES = .. lib_otpinf lib_sliceKIT_support
```

2.2 Allocating hardware resources

The Ethernet library requires several ports to communicate with the Ethernet PHY. These ports are declared in the main program file (`main.xc`). In this demo the ports are set up for the Ethernet slice connected to the CIRCLE slot of the sliceKIT:

```
// Here are the port definitions required by ethernet. This port assignment
// is for the L16 sliceKIT with the ethernet slice plugged into the
// CIRCLE slot.
port p_eth_rxclk = on tile[1]: XS1_PORT_1J;
port p_eth_rxd  = on tile[1]: XS1_PORT_4E;
port p_eth_txd  = on tile[1]: XS1_PORT_4F;
port p_eth_rxdv = on tile[1]: XS1_PORT_1K;
port p_eth_txen = on tile[1]: XS1_PORT_1L;
port p_eth_txcclk = on tile[1]: XS1_PORT_1I;
port p_eth_rxerr = on tile[1]: XS1_PORT_1P;
port p_eth_dummy = on tile[1]: XS1_PORT_8C;

clock eth_rxclk = on tile[1]: XS1_CLKBLK_1;
clock eth_txcclk = on tile[1]: XS1_CLKBLK_2;
```

Note that the port `p_eth_dummy` does not need to be connected to external hardware - it is just used internally by the Ethernet library.

The MDIO Serial Management Interface (SMI) is used to transfer management information between MAC and PHY. This interface consists of two signals which are connected to two ports:

```
port p_smi_mdio = on tile[1]: XS1_PORT_1M;
port p_smi_mdc  = on tile[1]: XS1_PORT_1N;
```

The final ports used in the application are the ones to access the internal OTP memory on the xCORE. These ports are fixed and can be initialized with the `OTP_PORTS_INITIALIZER` macro supplied by the `lib_otpinf` OTP reading library.

```
// These ports are for accessing the OTP memory
otp_ports_t otp_ports = on tile[0]: OTP_PORTS_INITIALIZER;
```

2.3 The application main() function

The main function in the program sets up the tasks in the application.

```
int main()
{
  ethernet_cfg_if i_cfg[NUM_CFG_CLIENTS];
  ethernet_rx_if i_rx[NUM_ETH_CLIENTS];
  ethernet_tx_if i_tx[NUM_ETH_CLIENTS];
  smi_if i_smi;

  par {
    on tile[1]: mii_ethernet_mac(i_cfg, NUM_CFG_CLIENTS,
                                i_rx, NUM_ETH_CLIENTS,
                                i_tx, NUM_ETH_CLIENTS,
                                p_eth_rxc1k, p_eth_rxerr,
                                p_eth_rxd, p_eth_rxdv,
                                p_eth_txc1k, p_eth_txen, p_eth_txd,
                                p_eth_dummy,
                                eth_rxc1k, eth_txc1k,
                                ETH_RX_BUFFER_SIZE_WORDS);

    on tile[1]: lan8710a_phy_driver(i_smi, i_cfg[CFG_TO_PHY_DRIVER]);

    on tile[1]: smi(i_smi, p_smi_mdio, p_smi_mdc);

    on tile[0]: icmp_server(i_cfg[CFG_TO_ICMP],
                           i_rx[ETH_TO_ICMP], i_tx[ETH_TO_ICMP],
                           ip_address, otp_ports);
  }
  return 0;
}
```

The `mii_ethernet_mac` communicates with the PHY and connects to the application via the three interfaces. It takes the previously declared ports as arguments as well as the required buffer size for the packet buffer within the MAC.

The `smi` task is part of the Ethernet library and controls the SMI protocol to configure the PHY. It connects to the `lan8710a_phy_driver` task which connects configuration of the PHY

2.4 The PHY driver

The PHY drive task connects to both the Ethernet MAC (via the `ethernet_cfg_if` interface for configuration) and the SMI driver (via the `smi_if` interface):

```
[[combinable]]
void lan8710a_phy_driver(client interface smi_if smi,
                        client interface ethernet_cfg_if eth) {
    ethernet_link_state_t link_state = ETHERNET_LINK_DOWN;
    ethernet_speed_t link_speed = LINK_100_MBPS_FULL_DUPLEX;
    const int link_poll_period_ms = 1000;
    const int phy_address = 0x0;
    timer tmr;
    int t;
    tmr :=> t;

    while (smi_phy_is_powered_down(smi, phy_address));
    smi_configure(smi, phy_address, LINK_100_MBPS_FULL_DUPLEX, SMI_ENABLE_AUTONEG);

    while (1) {
        select {
            case tmr when timerafter(t) :=> t:
                ethernet_link_state_t new_state = smi_get_link_state(smi, phy_address);
                // Read LAN8710A status register bit 2 to get the current link speed
                if ((new_state == ETHERNET_LINK_UP) &&
                    ((smi.read_reg(phy_address, 0x1F) >> 2) & 1)) {
                    link_speed = LINK_10_MBPS_FULL_DUPLEX;
                }
                else {
                    link_speed = LINK_100_MBPS_FULL_DUPLEX;
                }
                if (new_state != link_state) {
                    link_state = new_state;
                    eth.set_link_state(0, new_state, link_speed);
                }
                t += link_poll_period_ms * XS1_TIMER_KHZ;
                break;
        }
    }
}
```

The first action the drive does is wait for the PHY to power up and then configure the PHY. This is done via library functions provided by the Ethernet library.

The main body of the drive is an infinite loop that periodically reacts to a timer event in an `xC select` statement. At a set period it checks the state of the PHY over SMI and then informs the MAC of this state via the `eth.set_link_state` call. This way the MAC can know about link up/down events or change of link speed.

2.5 ICMP Packet Processing

The packet processing in the application is handled by the `icmp_server` task which is defined in the file `icmp.xc`. This function connects to the Ethernet MAC via a transmit, receive and configuration interface:

```
[[combinable]]
void icmp_server(client ethernet_cfg_if cfg,
                client ethernet_rx_if rx,
                client ethernet_tx_if tx,
                const unsigned char ip_address[4],
                otp_ports_t &otp_ports)
{
```

The first thing the task performs is configuring its connection to the MAC. The MAC address is configured by reading a MAC address out of OTP (using the `otp_board_info_get_mac` function from the OTP reading library) and then calling the `set_macaddr` interface function:

```

unsigned char mac_address[6];
ethernet_macaddr_filter_t macaddr_filter;

// Get the mac address from OTP and set it in the ethernet component
otp_board_info_get_mac(otp_ports, 0, mac_address);

size_t index = rx.get_index();
cfg.set_macaddr(0, mac_address);

```

After this, the task configures filters to determine which type of packets it will receive from the MAC:

```

memcpy(macaddr_filter.addr, mac_address, sizeof(mac_address));
cfg.add_macaddr_filter(index, 0, macaddr_filter);

// Add broadcast filter
memset(macaddr_filter.addr, 0xff, 6);
cfg.add_macaddr_filter(index, 0, macaddr_filter);

// Only allow ARP and IP packets to the app
cfg.add_ethertype_filter(index, 0x0806);
cfg.add_ethertype_filter(index, 0x0800);

```

The task then proceeds into an infinite loop that waits for a packet from the MAC and then processes it:

```

while (1)
{
  select {
  case rx.packet_ready():
    unsigned char rxbuf[ETHERNET_MAX_PACKET_SIZE];
    unsigned char txbuf[ETHERNET_MAX_PACKET_SIZE];
    ethernet_packet_info_t packet_info;
    rx.get_packet(packet_info, rxbuf, ETHERNET_MAX_PACKET_SIZE);

    if (packet_info.type != ETH_DATA)
      continue;

    if (is_valid_arp_packet(rxbuf, packet_info.len, ip_address))
    {
      int len = build_arp_response(rxbuf, txbuf, mac_address, ip_address);
      tx.send_packet(txbuf, len, ETHERNET_ALL_INTERFACES);
      debug_printf("ARP response sent\n");
    }
    else if (is_valid_icmp_packet(rxbuf, packet_info.len, ip_address))
    {
      int len = build_icmp_response(rxbuf, txbuf, mac_address, ip_address);
      tx.send_packet(txbuf, len, ETHERNET_ALL_INTERFACES);
      debug_printf("ICMP response sent\n");
    }
    break;
  }
}
}

```

The xC select statement will wait for the event rx.packet_ready() which is a receive notification from the MAC (see the Ethernet library user guide for details of the ethernet receive interface). When a packet arrives the rx.get_packet call will retrieve the packet from the MAC.

After the packet is processed the tx.send_packet call will send the created response packet to the MAC.

Details of the packet processing functions `is_valid_arp_packet`, `build_arp_response`, `is_valid_icmp_packet` and `build_icmp_response` can be found in the `icmp.xc` file. The functions implement the ICMP protocol.

APPENDIX A - Demo Hardware Setup

- To run the demo, connect the XTAG-2 USB debug adapter to the sliceKIT via the supplied adaptor board
- Connect the XTAG-2 to the host PC (using USB extension cable if desired)
- Connect the ethernet sliceCARD to the **CIRCLE** slot of the sliceKIT. Then, connect the slice to the host PC or to the network switch using an ethernet cable.
- On the xCORE-L series sliceKIT ensure that the xCONNECT LINK (xSCOPE) switch is set to ON, as per the image, to allow xSCOPE to function.

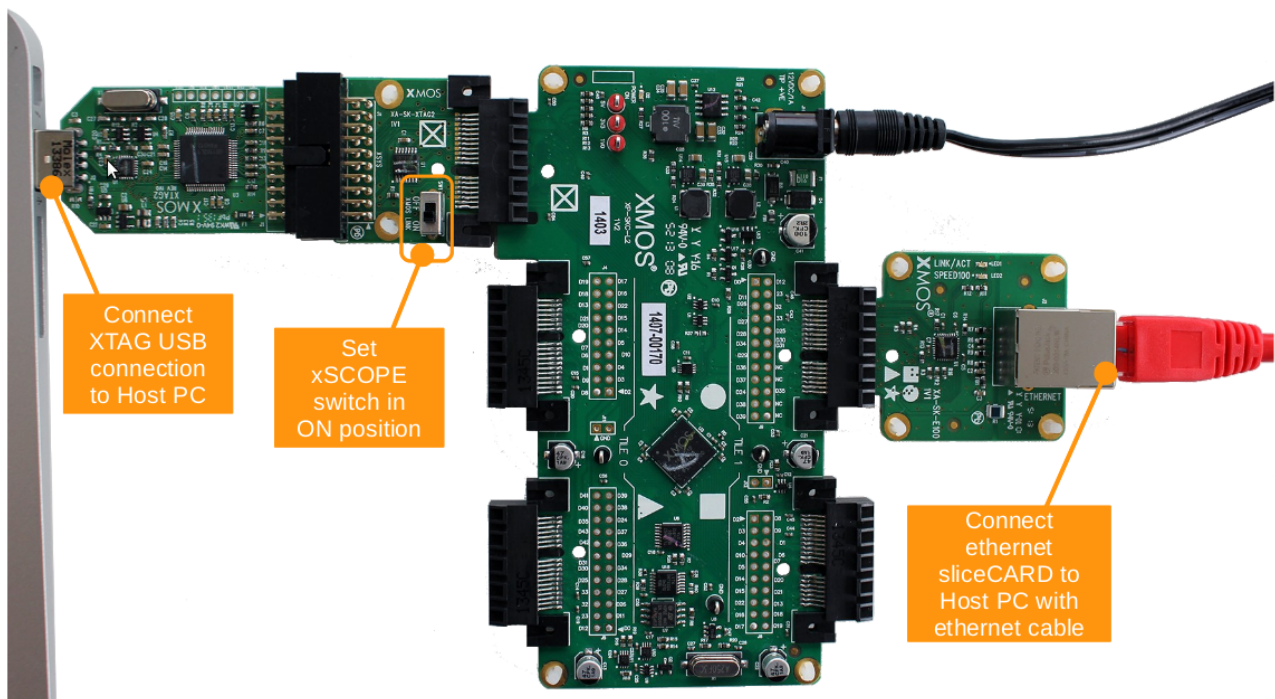

Figure 2: Hardware Setup for XMOS MAC library demo

APPENDIX B - Launching the demo device

Once the application source code is imported into the tools you can edit the demo to configure the IP address the ICMP code uses. This is declared as a data structure in `main.xc` (which is then passed to the `icmp_server` function):

```
static unsigned char ip_address[4] = {192, 168, 1, 178};
```

Alter this value to an IP address that works on your network.

You can now build the project which will generate the binary file required to run the demo application. Once the application has been built you need to download the application code onto the xCORE-L sliceKIT. Here you use the tools to load the application over JTAG onto the xCORE device.

- Select **Run Configuration**.
- In **Main** menu, enable **xSCOPE** in Target I/O options.
- In **XScope** menu, enable **Offline [XScope] Mode**.
- Click **Apply** and then **Run**.

When the processor has finished booting you will see the following text in the xTIMEcomposer console window when **ping**-ed from the host.

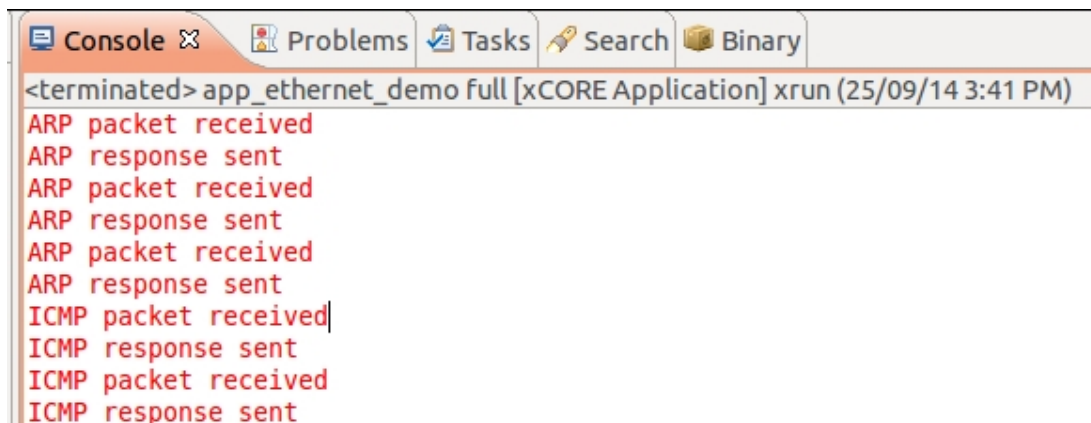

The screenshot shows the xTIMEcomposer console window with the following text:

```
<terminated> app_ethernet_demo full [xCORE Application] xrun (25/09/14 3:41 PM)
ARP packet received
ARP response sent
ARP packet received
ARP response sent
ARP packet received
ARP response sent
ICMP packet received
ICMP response sent
ICMP packet received
ICMP response sent
```

Figure 3: Response on xTIMEcomposer console for **Ping**

```

yuvaraj@yuvaraj-PC: ~
yuvaraj@yuvaraj-PC:~$ ping 169.254.8.100
PING 169.254.8.100 (169.254.8.100) 56(84) bytes of data.
From 169.254.8.175 icmp_seq=1 Destination Host Unreachable
From 169.254.8.175 icmp_seq=2 Destination Host Unreachable
From 169.254.8.175 icmp_seq=3 Destination Host Unreachable
From 169.254.8.175 icmp_seq=4 Destination Host Unreachable
From 169.254.8.175 icmp_seq=5 Destination Host Unreachable
From 169.254.8.175 icmp_seq=6 Destination Host Unreachable
From 169.254.8.175 icmp_seq=7 Destination Host Unreachable
From 169.254.8.175 icmp_seq=8 Destination Host Unreachable
From 169.254.8.175 icmp_seq=9 Destination Host Unreachable
From 169.254.8.175 icmp_seq=10 Destination Host Unreachable
From 169.254.8.175 icmp_seq=11 Destination Host Unreachable
From 169.254.8.175 icmp_seq=12 Destination Host Unreachable
From 169.254.8.175 icmp_seq=13 Destination Host Unreachable
From 169.254.8.175 icmp_seq=14 Destination Host Unreachable
From 169.254.8.175 icmp_seq=15 Destination Host Unreachable
^C
--- 169.254.8.100 ping statistics ---
40 packets transmitted, 0 received, +15 errors, 100% packet loss, time 39270ms
pipe 3
yuvaraj@yuvaraj-PC:~$
  
```

Figure 4: Response on Host PC for Ping

On the above *ping* response on host, out of 40 packets transmitted to device first 15 packet couldn't able to reach the device. During this period, device will respond as **ARP packet received**. After that device (remaining 35 packets) responds as **ICMP packet received**. (Figure 3)

APPENDIX C - FAQs

1. What do I do if I need to change the ethernet sliceCARD slot?

The ports in the application are configured to connect to ethernet sliceCARD in the CIRCLE slot but this can be changed by changing the port declarations in `main.xc`.

2. How can the demo be altered to use the real-time MAC?

The call to `mii_ethernet_mac` needs to be replaced with a call to `mii_ethernet_rt_mac`. See the Ethernet library user guide for more details.

3. What are Buffers and Queues? Why are they needed?

The MAC maintains two sets of buffers: one for the incoming packets and the other for outgoing packets.

For the incoming packets:

- Empty buffers are in the incoming queue awaiting a packet coming from the MII interfaces.
- Buffers received from the MII interface are filtered and moved into a forwarding queue if appropriate.
- Buffers in the forwarding queue are moved into a client queue depending on which client registered for that type of packet.
- Once the data from a buffer has been sent to a client, the buffer is moved back into the incoming queue.

For the outgoing packets:

- Empty buffers are stored in an empty queue awaiting a packet from the client.
- Once the data is received the buffer is moved into a transmit queue awaiting output on the MII interface.
- Once the data is transmitted, the buffer is released back to the empty queue.

APPENDIX D - References

XMOS Tools User Guide

<http://www.xmos.com/published/xtimecomposer-user-guide>

XMOS xCORE Programming Guide

<http://www.xmos.com/published/xmos-programming-guide>

XMOS Layer 2 Ethernet MAC Component

<https://www.xmos.com/published/xmos-layer-2-ethernet-mac-component>

IEEE 802.3 Ethernet Standards

<http://standards.ieee.org/about/get/802/802.3.html>

Ethernet Basics

http://homepage.smc.edu/morgan_david/linux/n-protocol-09-ethernet.pdf

Ethernet Frame

http://en.wikipedia.org/wiki/Ethernet_frame

Ethernet Timestamps

http://m.eetindia.co.in/STATIC/PDF/200906/EEIOL_2009JUN03_NETD_TA_01.pdf?SOURCES=DOWNLOAD

MAC address

http://en.wikipedia.org/wiki/MAC_address

Ethernet Type

<http://en.wikipedia.org/wiki/EtherType>

Internet Control Message Protocol

http://en.wikipedia.org/wiki/Internet_Control_Message_Protocol

APPENDIX E - Full Source code listing

E.1 Source code for main.xc

```

// Copyright (c) 2015, XMOS Ltd, All rights reserved
#include <xs1.h>
#include <platform.h>
#include "otp_board_info.h"
#include "ethernet.h"
#include "icmp.h"
#include "smi.h"

// Here are the port definitions required by ethernet. This port assignment
// is for the L16 sliceKIT with the ethernet slice plugged into the
// CIRCLE slot.
port p_eth_rxc1k = on tile[1]: XS1_PORT_1J;
port p_eth_rxd = on tile[1]: XS1_PORT_4E;
port p_eth_txd = on tile[1]: XS1_PORT_4F;
port p_eth_rxdv = on tile[1]: XS1_PORT_1K;
port p_eth_txen = on tile[1]: XS1_PORT_1L;
port p_eth_txc1k = on tile[1]: XS1_PORT_1I;
port p_eth_rxerr = on tile[1]: XS1_PORT_1P;
port p_eth_dummy = on tile[1]: XS1_PORT_8C;

clock eth_rxc1k = on tile[1]: XS1_CLKBLK_1;
clock eth_txc1k = on tile[1]: XS1_CLKBLK_2;

port p_smi_mdio = on tile[1]: XS1_PORT_1M;
port p_smi_mdc = on tile[1]: XS1_PORT_1N;

// These ports are for accessing the OTP memory
otp_ports_t otp_ports = on tile[0]: OTP_PORTS_INITIALIZER;

static unsigned char ip_address[4] = {192, 168, 1, 178};

// An enum to manage the array of connections from the ethernet component
// to its clients.
enum eth_clients {
  ETH_TO_ICMP,
  NUM_ETH_CLIENTS
};

enum cfg_clients {
  CFG_TO_ICMP,
  CFG_TO_PHY_DRIVER,
  NUM_CFG_CLIENTS
};

[[combinable]]
void lan8710a_phy_driver(client interface smi_if smi,
                        client interface ethernet_cfg_if eth) {
  ethernet_link_state_t link_state = ETHERNET_LINK_DOWN;
  ethernet_speed_t link_speed = LINK_100_MBPS_FULL_DUPLEX;
  const int link_poll_period_ms = 1000;
  const int phy_address = 0x0;
  timer_tmr;
  int t;
  tmr := t;

  while (smi_phy_is_powered_down(smi, phy_address));
  smi_configure(smi, phy_address, LINK_100_MBPS_FULL_DUPLEX, SMI_ENABLE_AUTONEG);

  while (1) {
    select {
      case tmr when timerafter(t) := t:
        ethernet_link_state_t new_state = smi_get_link_state(smi, phy_address);
        // Read LAN8710A status register bit 2 to get the current link speed
        if ((new_state == ETHERNET_LINK_UP) &&
            ((smi.read_reg(phy_address, 0x1F) >> 2) & 1)) {
          link_speed = LINK_10_MBPS_FULL_DUPLEX;
        }
    }
  }
}

```

```

    else {
        link_speed = LINK_100_MBPS_FULL_DUPLEX;
    }
    if (new_state != link_state) {
        link_state = new_state;
        eth.set_link_state(0, new_state, link_speed);
    }
    t += link_poll_period_ms * XS1_TIMER_KHZ;
    break;
}
}
}

#define ETH_RX_BUFFER_SIZE_WORDS 1600

int main()
{
    ethernet_cfg_if i_cfg[NUM_CFG_CLIENTS];
    ethernet_rx_if i_rx[NUM_ETH_CLIENTS];
    ethernet_tx_if i_tx[NUM_ETH_CLIENTS];
    smi_if i_smi;

    par {
        on tile[1]: mii_ethernet_mac(i_cfg, NUM_CFG_CLIENTS,
                                   i_rx, NUM_ETH_CLIENTS,
                                   i_tx, NUM_ETH_CLIENTS,
                                   p_eth_rxc1k, p_eth_rxerr,
                                   p_eth_rxd, p_eth_rxdv,
                                   p_eth_txc1k, p_eth_txen, p_eth_txd,
                                   p_eth_dummy,
                                   eth_rxc1k, eth_txc1k,
                                   ETH_RX_BUFFER_SIZE_WORDS);

        on tile[1]: lan8710a_phy_driver(i_smi, i_cfg[CFG_TO_PHY_DRIVER]);

        on tile[1]: smi(i_smi, p_smi_mdio, p_smi_mdc);

        on tile[0]: icmp_server(i_cfg[CFG_TO_ICMP],
                               i_rx[ETH_TO_ICMP], i_tx[ETH_TO_ICMP],
                               ip_address, otp_ports);
    }
    return 0;
}

```

E.2 Source code for icmp.xc

```

// Copyright (c) 2015, XMOS Ltd, All rights reserved
#include <debug_print.h>
#include <xclib.h>
#include <stdint.h>
#include <ethernet.h>
#include <otp_board_info.h>
#include <string.h>

static unsigned short checksum_ip(const unsigned char frame[34])
{
    int i;
    unsigned accum = 0;

    for (i = 14; i < 34; i += 2)
    {
        accum += *((const uint16_t*)(frame + i));
    }

    // Fold carry into 16bits
    while (accum >> 16)
    {
        accum = (accum & 0xFFFF) + (accum >> 16);
    }

    accum = byterev(~accum) >> 16;

    return accum;
}

```

```

}

static int build_arp_response(unsigned char rxbuf[64],
                             unsigned char txbuf[64],
                             const unsigned char own_mac_addr[6],
                             const unsigned char own_ip_addr[4])
{
  unsigned word;
  unsigned char byte;

  for (int i = 0; i < 6; i++)
  {
    byte = rxbuf[22+i];
    txbuf[i] = byte;
    txbuf[32 + i] = byte;
  }
  word = ((const unsigned int *) rxbuf)[7];
  for (int i = 0; i < 4; i++)
  {
    txbuf[38 + i] = word & 0xFF;
    word >>= 8;
  }

  txbuf[28] = own_ip_addr[0];
  txbuf[29] = own_ip_addr[1];
  txbuf[30] = own_ip_addr[2];
  txbuf[31] = own_ip_addr[3];

  for (int i = 0; i < 6; i++)
  {
    txbuf[22 + i] = own_mac_addr[i];
    txbuf[6 + i] = own_mac_addr[i];
  }
  txbuf[12] = 0x08;
  txbuf[13] = 0x06;
  txbuf[14] = 0x00;
  txbuf[15] = 0x01;
  txbuf[16] = 0x08;
  txbuf[17] = 0x00;
  txbuf[18] = 0x06;
  txbuf[19] = 0x04;
  txbuf[20] = 0x00;
  txbuf[21] = 0x02;

  // Typically 48 bytes (94 for IPv6)
  for (int i = 42; i < 64; i++)
  {
    txbuf[i] = 0x00;
  }

  return 64;
}

static int is_valid_arp_packet(const unsigned char rxbuf[nbytes],
                              unsigned nbytes,
                              const unsigned char own_ip_addr[4])
{
  if (rxbuf[12] != 0x08 || rxbuf[13] != 0x06)
    return 0;

  debug_printf("ARP packet received\n");

  if (((const unsigned int *) rxbuf)[3] != 0x01000608)
  {
    debug_printf("Invalid et_hatype\n");
    return 0;
  }
  if (((const unsigned int *) rxbuf)[4] != 0x04060008)
  {
    debug_printf("Invalid ptype_hlen\n");
    return 0;
  }
  if (((const unsigned int *) rxbuf)[5] & 0xFFFF) != 0x0100)

```

```

{
    debug_printf("Not a request\n");
    return 0;
}
for (int i = 0; i < 4; i++)
{
    if (rxbuf[38 + i] != own_ip_addr[i])
    {
        debug_printf("Not for us\n");
        return 0;
    }
}
return 1;
}

static int build_icmp_response(unsigned char rxbuf[], unsigned char txbuf[],
                             const unsigned char own_mac_addr[6],
                             const unsigned char own_ip_addr[4])
{
    unsigned icmp_checksum;
    int datalen;
    int totallen;
    const int ttl = 0x40;
    int pad;

    // Precomputed empty IP header checksum (inverted, bytoreversed and shifted right)
    unsigned ip_checksum = 0x0185;

    for (int i = 0; i < 6; i++)
    {
        txbuf[i] = rxbuf[6 + i];
    }
    for (int i = 0; i < 4; i++)
    {
        txbuf[30 + i] = rxbuf[26 + i];
    }
    icmp_checksum = byterevert(((const unsigned int *) rxbuf)[9]) >> 16;
    for (int i = 0; i < 4; i++)
    {
        txbuf[38 + i] = rxbuf[38 + i];
    }
    totallen = byterevert(((const unsigned int *) rxbuf)[4]) >> 16;
    datalen = totallen - 28;
    for (int i = 0; i < datalen; i++)
    {
        txbuf[42 + i] = rxbuf[42+i];
    }

    for (int i = 0; i < 6; i++)
    {
        txbuf[6 + i] = own_mac_addr[i];
    }
    ((unsigned int *) txbuf)[3] = 0x00450008;
    totallen = byterevert(28 + datalen) >> 16;
    ((unsigned int *) txbuf)[4] = totallen;
    ip_checksum += totallen;
    ((unsigned int *) txbuf)[5] = 0x01000000 | (ttl << 16);
    ((unsigned int *) txbuf)[6] = 0;
    for (int i = 0; i < 4; i++)
    {
        txbuf[26 + i] = own_ip_addr[i];
    }
    ip_checksum += (own_ip_addr[0] | own_ip_addr[1] << 8);
    ip_checksum += (own_ip_addr[2] | own_ip_addr[3] << 8);
    ip_checksum += txbuf[30] | (txbuf[31] << 8);
    ip_checksum += txbuf[32] | (txbuf[33] << 8);

    txbuf[34] = 0x00;
    txbuf[35] = 0x00;

    icmp_checksum = (icmp_checksum + 0x0800);
    icmp_checksum += icmp_checksum >> 16;
    txbuf[36] = icmp_checksum >> 8;
}

```



```

txbuf[37] = icmp_checksum & 0xFF;

while (ip_checksum >> 16)
{
    ip_checksum = (ip_checksum & 0xFFFF) + (ip_checksum >> 16);
}
ip_checksum = bytorev(~ip_checksum) >> 16;
txbuf[24] = ip_checksum >> 8;
txbuf[25] = ip_checksum & 0xFF;

for (pad = 42 + datalen; pad < 64; pad++)
{
    txbuf[pad] = 0x00;
}
return pad;
}

static int is_valid_icmp_packet(const unsigned char rxbuf[nbytes],
                               unsigned nbytes,
                               const unsigned char own_ip_addr[4])
{
    unsigned totallen;
    if (rxbuf[23] != 0x01)
        return 0;

    debug_printf("ICMP packet received\n");

    if (((const unsigned int *) rxbuf)[3] != 0x00450008)
    {
        debug_printf("Invalid et_ver_hdr1_tos\n");
        return 0;
    }
    if (((const unsigned int *) rxbuf)[8] >> 16) != 0x0008)
    {
        debug_printf("Invalid type_code\n");
        return 0;
    }
    for (int i = 0; i < 4; i++)
    {
        if (rxbuf[30 + i] != own_ip_addr[i])
        {
            debug_printf("Not for us\n");
            return 0;
        }
    }

    totallen = bytorev(((const unsigned int *) rxbuf)[4]) >> 16;
    if (nbytes > 60 && nbytes != totallen + 14)
    {
        debug_printf("Invalid size (nbytes:%d, totallen:%d)\n", nbytes, totallen+14);
        return 0;
    }
    if (checksum_ip(rxbuf) != 0)
    {
        debug_printf("Bad checksum\n");
        return 0;
    }

    return 1;
}

[[combinable]]
void icmp_server(client ethernet_cfg_if cfg,
                client ethernet_rx_if rx,
                client ethernet_tx_if tx,
                const unsigned char ip_address[4],
                otp_ports_t &otp_ports)
{
    unsigned char mac_address[6];
    ethernet_macaddr_filter_t macaddr_filter;

    // Get the mac address from OTP and set it in the ethernet component
    otp_board_info_get_mac(otp_ports, 0, mac_address);
}

```

```

size_t index = rx.get_index();
cfg.set_macaddr(0, mac_address);

memcpy(macaddr_filter.addr, mac_address, sizeof(mac_address));
cfg.add_macaddr_filter(index, 0, macaddr_filter);

// Add broadcast filter
memset(macaddr_filter.addr, 0xff, 6);
cfg.add_macaddr_filter(index, 0, macaddr_filter);

// Only allow ARP and IP packets to the app
cfg.add_ethertype_filter(index, 0x0806);
cfg.add_ethertype_filter(index, 0x0800);

debug_printf("Test started\n");
while (1)
{
  select {
  case rx.packet_ready():
    unsigned char rxbuf[ETHERNET_MAX_PACKET_SIZE];
    unsigned char txbuf[ETHERNET_MAX_PACKET_SIZE];
    ethernet_packet_info_t packet_info;
    rx.get_packet(packet_info, rxbuf, ETHERNET_MAX_PACKET_SIZE);

    if (packet_info.type != ETH_DATA)
      continue;

    if (is_valid_arp_packet(rxbuf, packet_info.len, ip_address))
    {
      int len = build_arp_response(rxbuf, txbuf, mac_address, ip_address);
      tx.send_packet(txbuf, len, ETHERNET_ALL_INTERFACES);
      debug_printf("ARP response sent\n");
    }
    else if (is_valid_icmp_packet(rxbuf, packet_info.len, ip_address))
    {
      int len = build_icmp_response(rxbuf, txbuf, mac_address, ip_address);
      tx.send_packet(txbuf, len, ETHERNET_ALL_INTERFACES);
      debug_printf("ICMP response sent\n");
    }
    break;
  }
}
}

```

Xmos Ltd. is the owner or licensee of this design, code, or Information (collectively, the "Information") and is providing it to you "AS IS" with no warranty of any kind, express or implied and shall have no liability in relation to its use. Xmos Ltd. makes no representation that the Information, or any particular implementation thereof, is or will be free from any claims of infringement and again, shall have no liability in relation to any such claims.
